

Unlocking Loudness

Andrew Mason
BBC Research and Development

IEC 60268-10

IEC 60268-17

BS 6840-10 EBU Tech. 3205

PPM

BS 6840-17

ITU-R BS.1770

CENELEC HD 483.17 S1

CENELEC HD 483.10 S1

VU

Type II a

Numberwang

| ITU-R BS.1770

“Algorithms to measure audio programme loudness
and to measure true-peak audio level”

ITU-R BS.1770

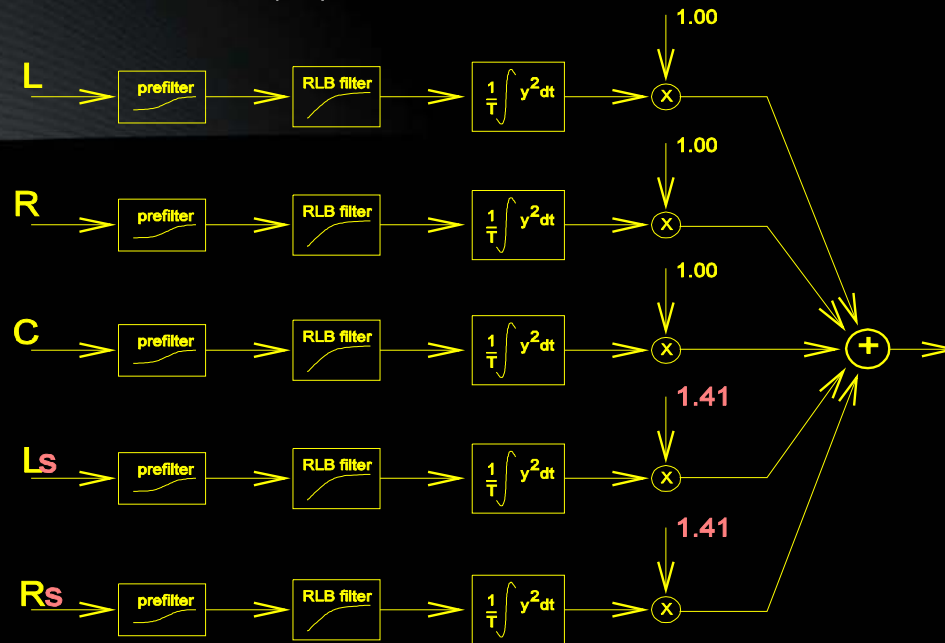
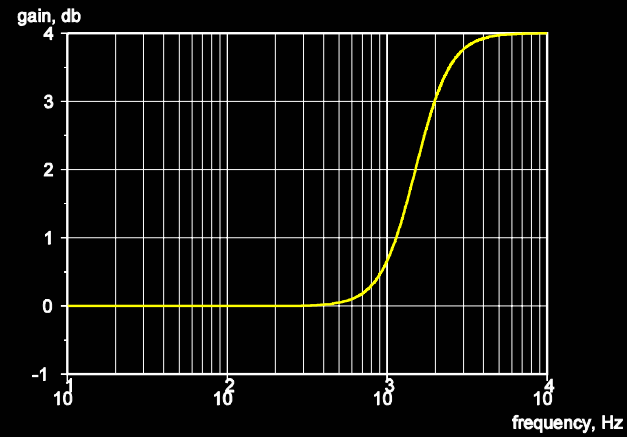
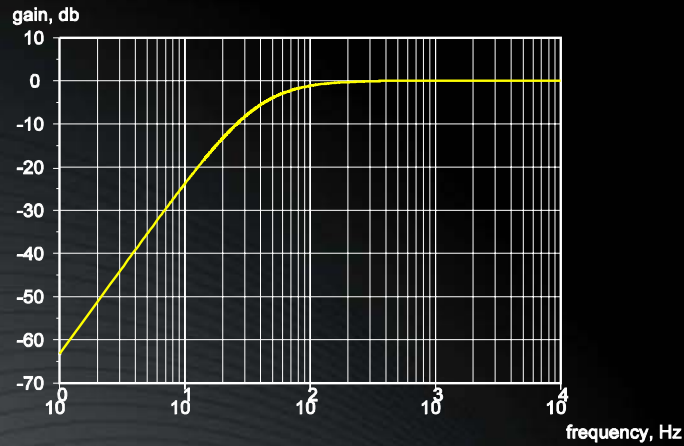

ITU-R BS.1770 – RLB filter

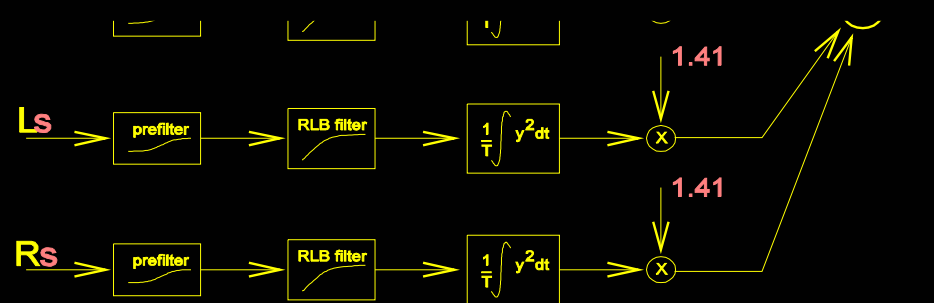
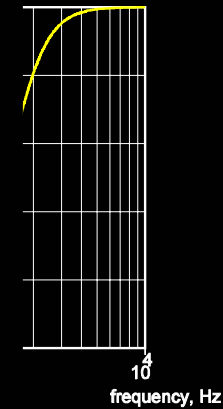
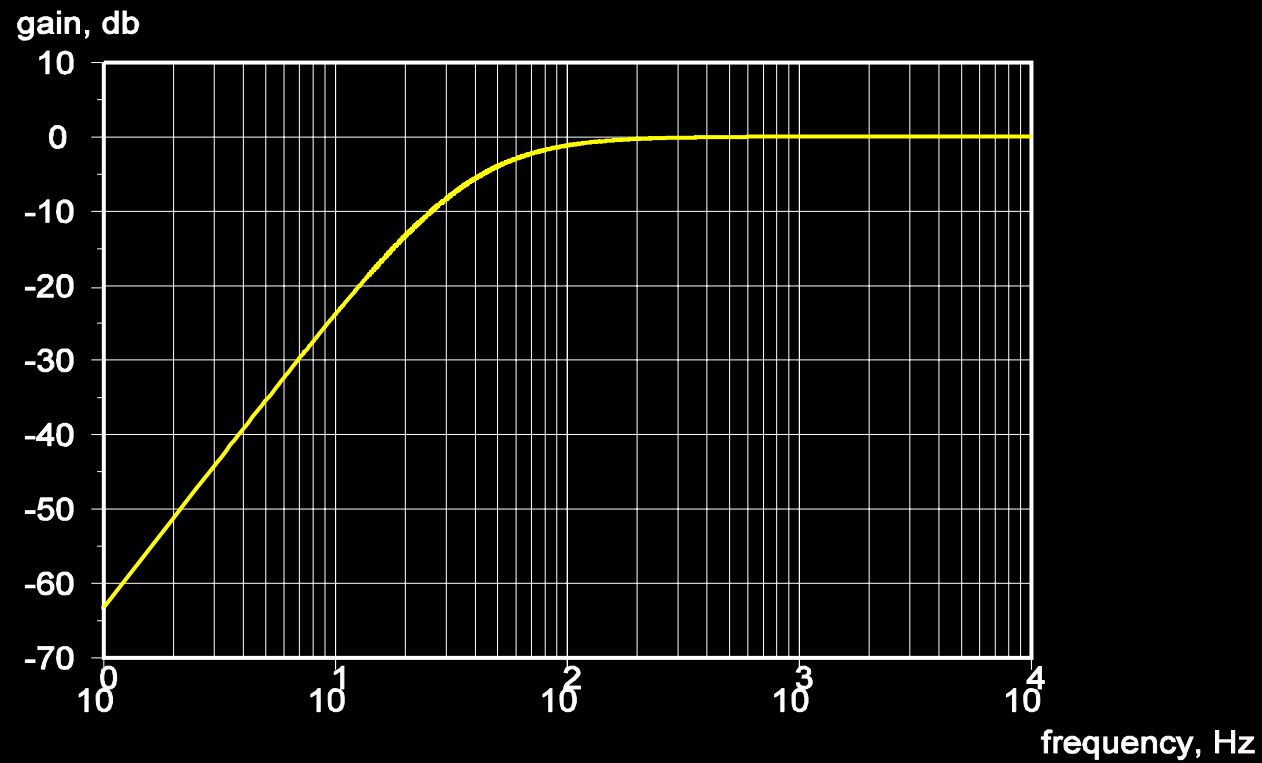

ITU-R BS.1770 – HRTF pre-filter

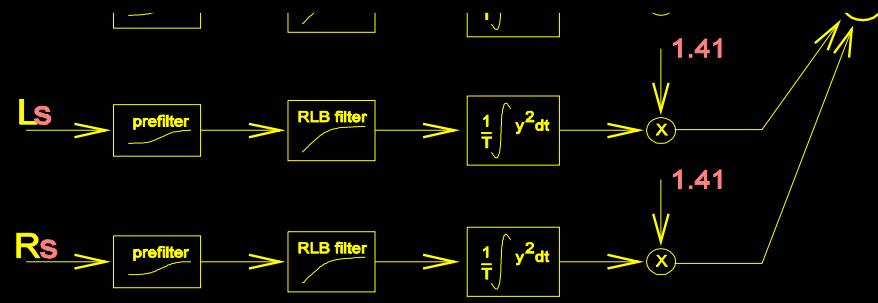
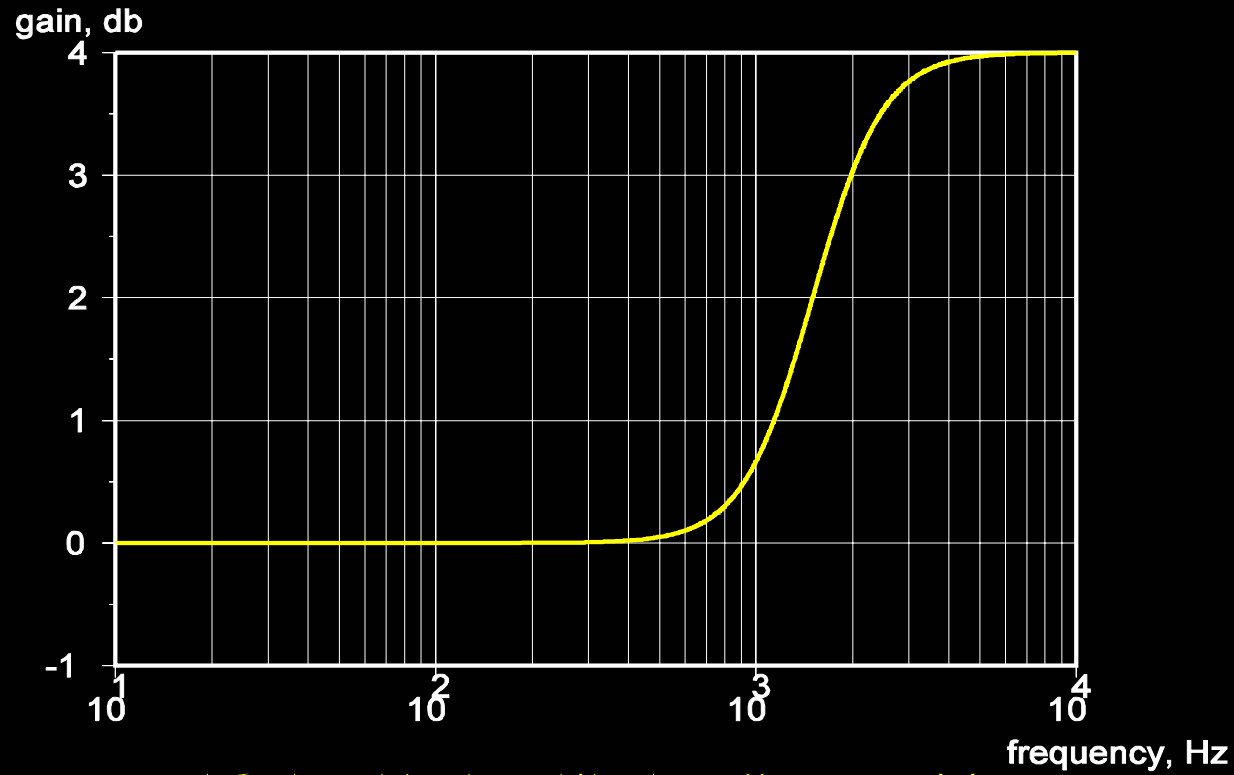

ITU-R BS.1770 – averaging, channel sum

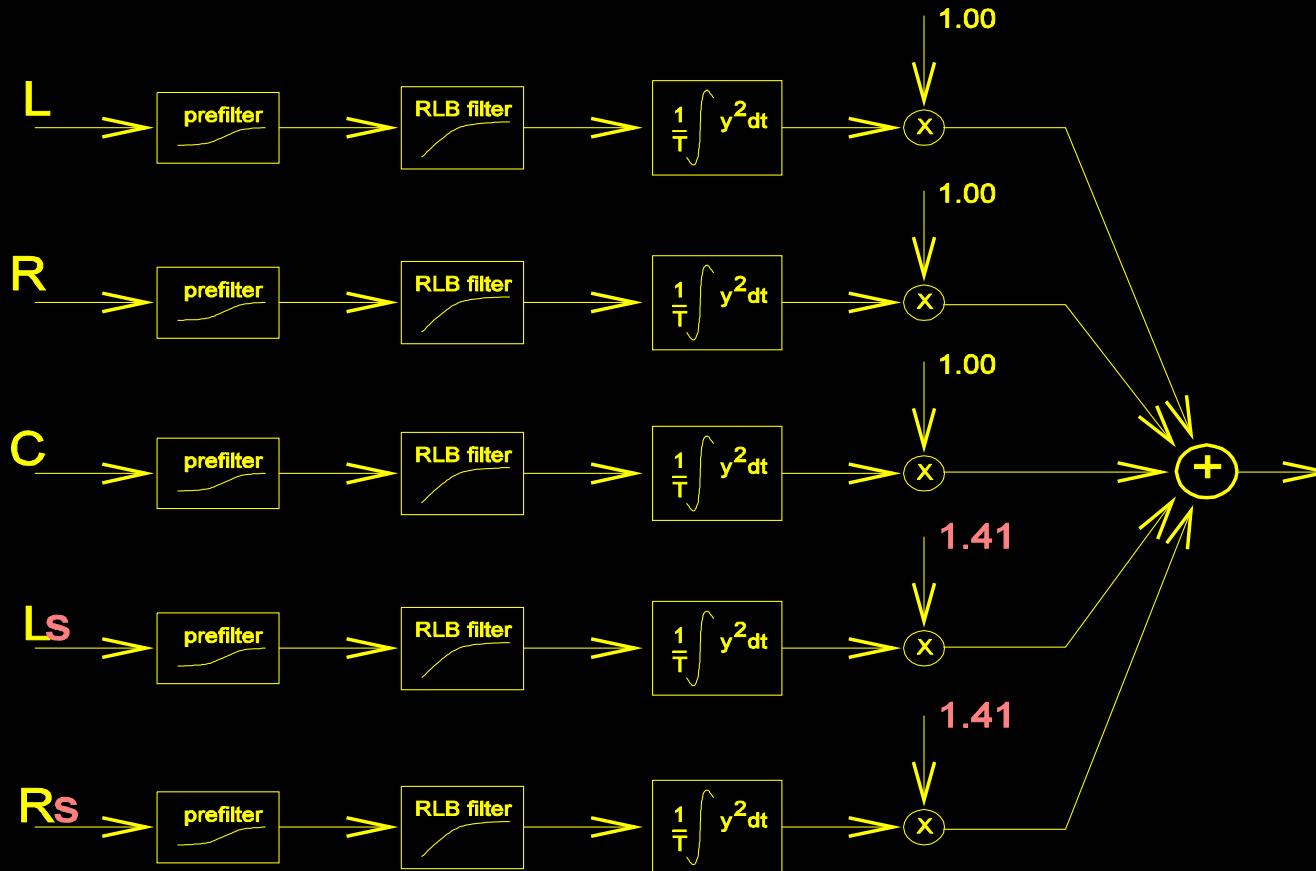
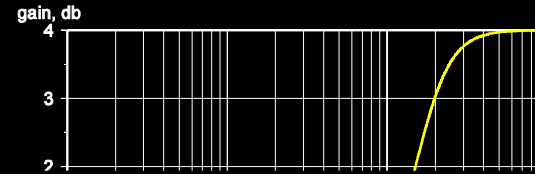
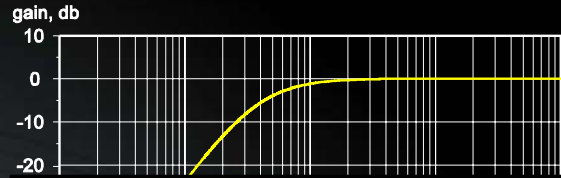

| The maths

$$i\hbar \frac{\partial}{\partial t} \Psi(r, t) = -\frac{\hbar^2}{2m} \nabla^2 \Psi(r, t) + V(r) \Psi(r, t)$$

| The maths

$$\text{Loudness} = -0.691 + 10 \log_{10} \sum_i^N G_i \cdot z_i$$

G_i are channel weightings

z_i are averaged squared filtered sample values

i is L, R, C, L_s, R_s

Unit is LKFS

ITU-R BS.1770

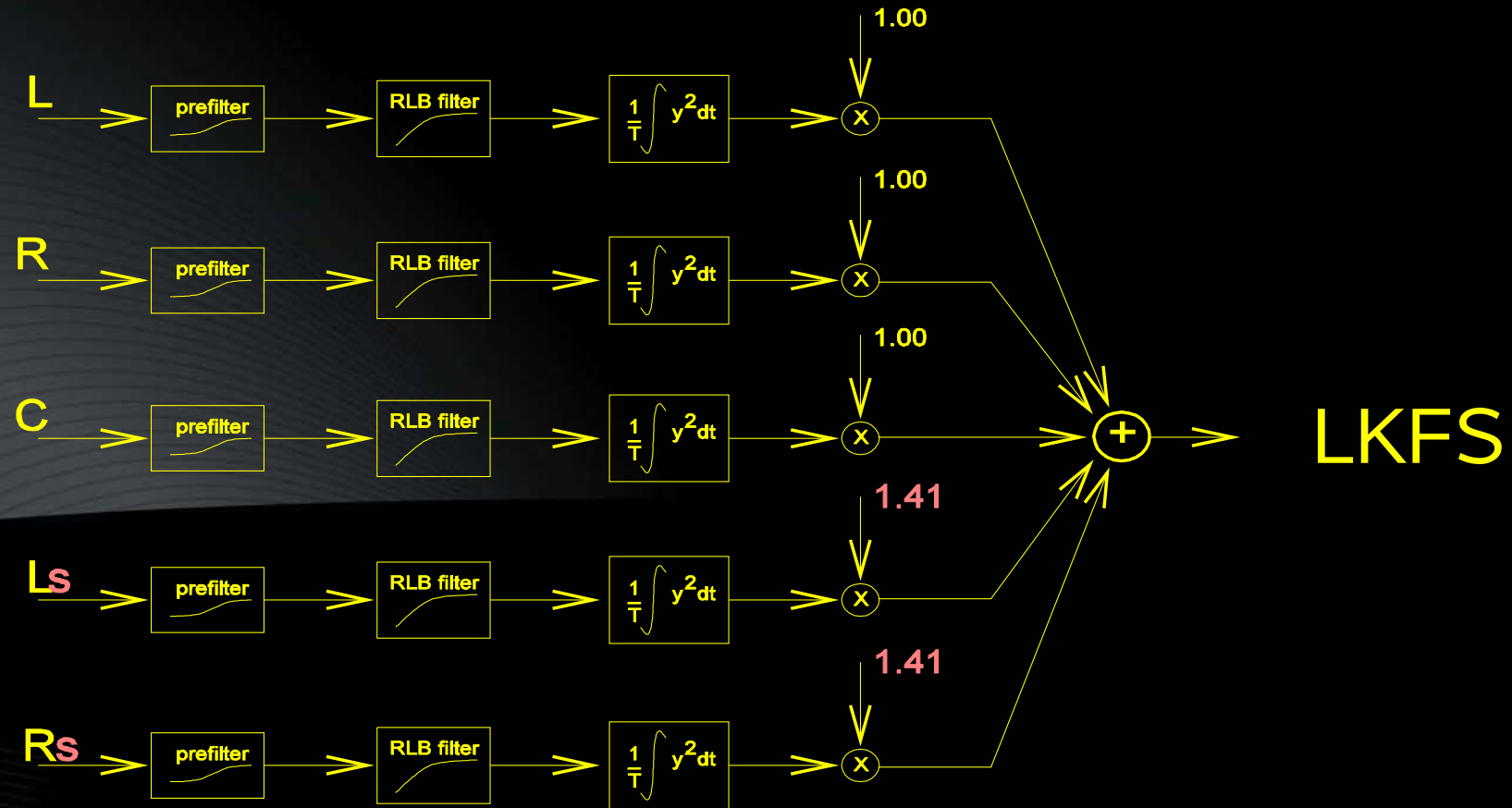



Abū 'Abdallāh Muḥammad ibn Mūsā al-Khwārizmī
محمد بن موسى الخوارزميّ المجوسيّ القطرّبليّ

| Homework

- Soulodre, “Evaluation of Objective Loudness Meters,” 116th AES, Pre-print 6161, 2004
- Lavoie and Soulodre, “Stereo and Multichannel Loudness Perception and Metering,” 119th AES, Pre-print 6618, 2005
- Seefeldt and Lyman, “A Comparison of Various Multichannel Loudness Measurement Techniques,” 121st AES, Pre-print 6918, 2006
- ITU-R BS.1770
- ITU-R BS.1771

| BCAP TV Advertising Standards Code

Advertisements must not be excessively noisy or strident. The maximum subjective loudness of advertisements must be consistent and in line with the maximum loudness of programmes and junction material.

Broadcasters must endeavour to minimise annoyance that perceived imbalances could cause, with the aim that the audience need not adjust the volume ... during programme breaks. For editorial reasons, however, commercial breaks sometimes occur during especially quiet parts of the programme, with the result that advertisements at normally acceptable levels seem loud in comparison.

| BCAP TV Advertising Standards Code

Measurement and balancing of subjective loudness levels should preferably be carried out using a loudness-level meter, ideally conforming to ITU recommendations¹. If a peak-reading meter² is used instead, the maximum level of the advertisements must be at least 6dB less than the maximum level of the programmes³ to take account of the limited dynamic range exhibited by most advertisements.

(3) Normal convention for analogue audio is that the peak sound level of programmes is set to be no higher than +8dBm, ... '6' on a peak-reading meter. The peak sound level of advertisements should therefore be limited to +2dBm or '4.5' on a peak-reading meter.
Note: +8dBm corresponds to ... -10dB relative to digital clipping level.

BCAP TV Advertising Standards Code

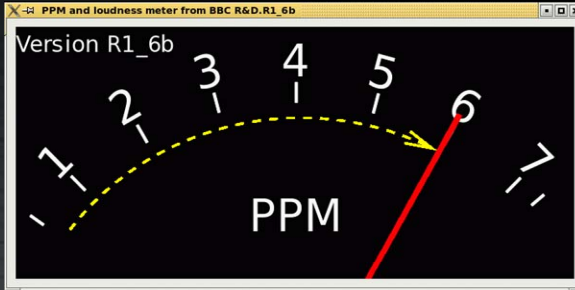

programme

and

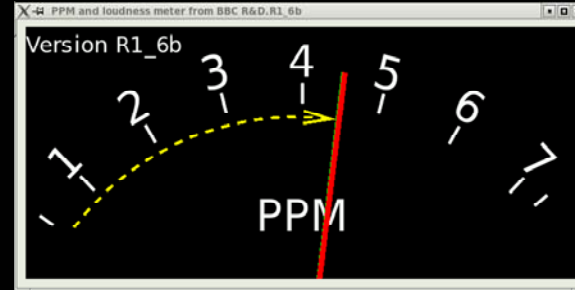

advertisement

or

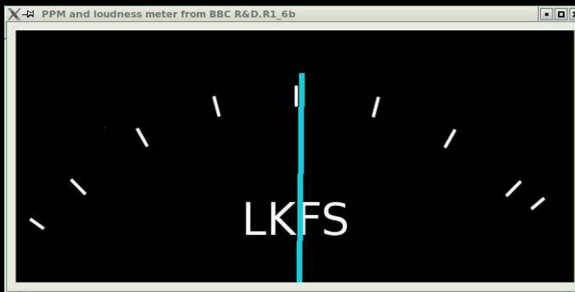

programme

and



advertisement

Operational approaches

Fox Italia HD Tech. Spec.

Loudness (LKFS):

	Channels	Average	Max	Min
Programme	Stereo	-24	-20	-28
	5.1	-25	-18	-30
Advert	Stereo	(-24)	-22	-26
	5.1	(-25)	-20	-28

-8dB true peak limit
downmix and other metadata tables

| Operational approaches

VRT

- metering – one type of meter;
- monitoring – fixed reproduction gain;
- modulation – guidelines on max and min;
- processing – a few presets for dynamics processors.

| Metadata

“dialnorm”

from Dolby E and Dolby Digital (AC-3)

“prog_ref_level”

from MPEG 4 Audio (ISO/IEC 14496-3)

New meters



New meters

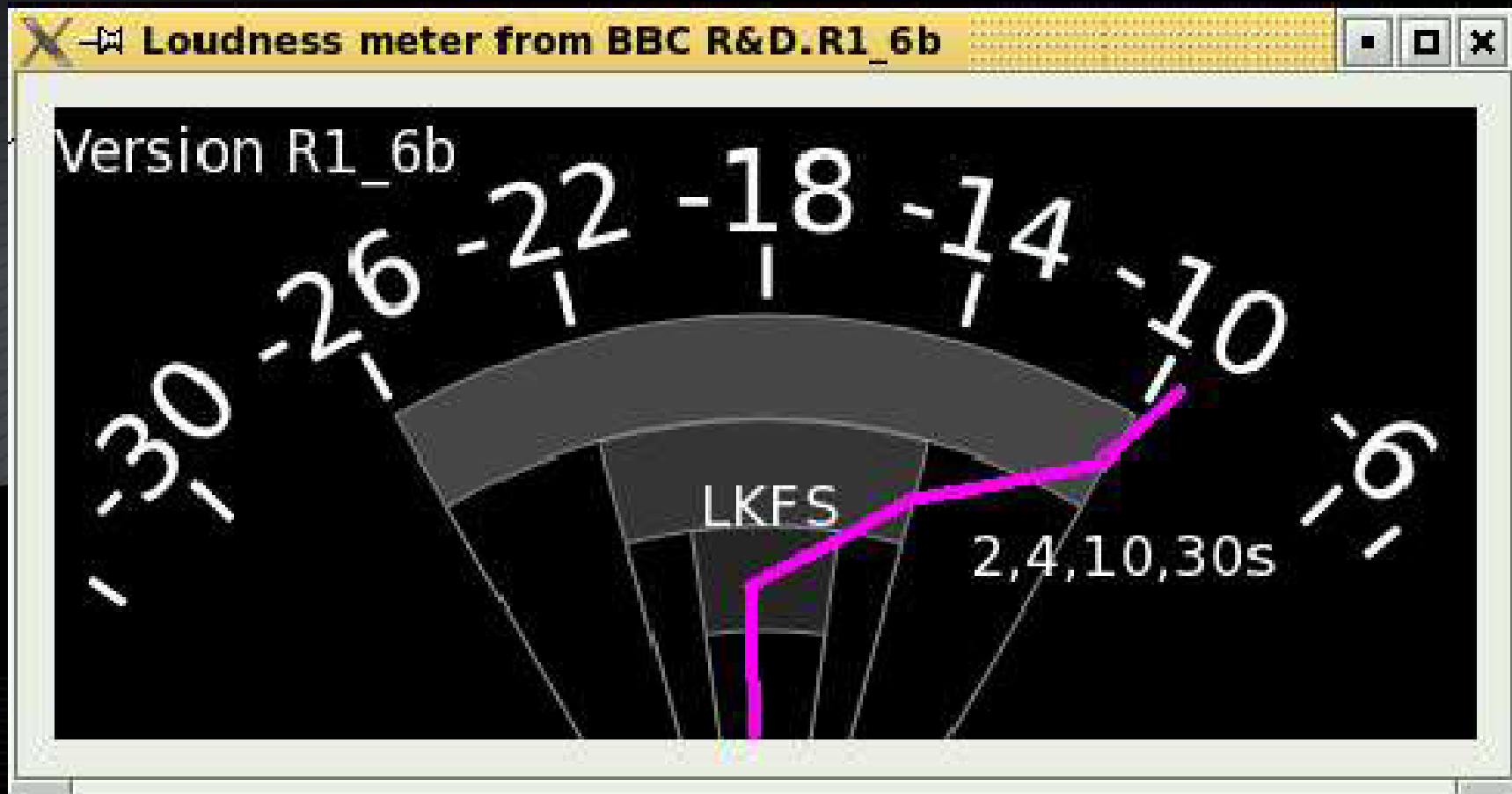

(<http://sf.net/projects/baptools>)

|Where is it all happening?



EBU technical project group P/LOUD